

PowerSoft

DIGAM®

SERIES

Digital Audio Amplifier
for Professional Applications

User Manual

Table of Contents

IMPORTANT	3
WARNING NOTICES	3
INTRODUCTION	5
INSTALLATION AND OPERATION	6
UNPACKING	6
MOUNTING	6
OPERATING PRECAUTIONS	6
CONNECTING INPUTS	6
CONNECTING OUTPUTS	6
CONTROLS	7
INPUT ATTENUATORS	7
LED INDICATORS AND CONTROLS	7
LED INDICATORS	7
FRONT PANEL CONTROLS	7
PROTECTION	8
TURN-ON/TURN-OFF MUTING	8
SHORT CIRCUIT PROTECTION	8
THERMAL PROTECTION	8
DC FAULT PROTECTION	8
INPUT/OUTPUT PROTECTION	9
USER MAINTENANCE	9
WARRANTY AND DISCLAIMERS	9
DISCLAIMER	9
PRODUCT WARRANTY	9
TECHNICAL ASSISTANCE AND SERVICE	9
TECHNICAL ASSISTANCE	10
FACTORY SERVICE	10
INTERNATIONAL SERVICING	10
TECHNICAL NOTES	11
DIGAM 3000	12
GENERAL	12
AUDIO SECTION	12
FUNCTIONS	12
DIGAM 5000	13
GENERAL	13
AUDIO SECTION	13
FUNCTIONS	13
DIGAM 7000	14
GENERAL	14
AUDIO SECTION	14
FUNCTIONS	14

Important



CAUTION: To reduce the risk of electric shock, do not remove the cover. No user-serviceable parts inside. Refer servicing to qualified service personnel.

WARNING: To prevent fire or electric shock, do not expose this equipment to rain or moisture.

SAFEGUARDS: Electrical energy can perform many useful functions. This unit has been engineered and manufactured to assure your personal safety. Improper use can result in potential electrical shock or fire hazards. In order not to defeat the safeguards, observe the following instructions for its installation, use and servicing.

NOTES:

This equipment has been tested and found to comply by Competent Body (Directive 89/336/EEC-EMC) pursuant to the product family standard for audio professional use:

EN 55103-1 and EN 55103-2 standard (with the limits for E1 and E2 electromagnetic environment); EN61000- 3 – 2, EN

This equipment has been tested and found to comply by Notyfed Body (Directive 73/23/EEC L.V) pursuant to the audio apparatus safety requirements:

Standard EN 60065.

Warning Notices

LOCATION

Install the amplifier in a well-ventilated location where it will not be exposed to high temperature or humidity.

Do not install the amplifier in a location that is exposed to direct rays of the sun, or near to hot appliances or radiators. Excessive heat can adversely affect the cabinet and internal components. Installation of the amplifier in a damp or dusty environment may result in malfunction or accident.

PRECAUTIONS REGARDING INSTALLATION

Placing and using the amplifier for long periods on heat-generation sources will affect performances. Avoid placing the amplifier on heat-generating sources.

Install this amplifier as far as possible from tuners and TV sets. An amplifier installed in close proximity to such equipment may cause noise or degradation of the picture.

SAFETY RULES

This device must be powered exclusively by earth connected mains sockets in electrical networks compliant to the IEC 364 or similar rules. Is absolutely necessary to verify this fundamental requirement of safety and, in case of doubt, require an accurate check by a qualified personal. The constructor cannot be considered responsible for eventual damages caused to persons, things or data for the missing of accurate earth link. Before powering this device verify that the amplifier is supplied with the correct voltage rating.

Verify that your main connection is capable to satisfy the power ratings of the device.

Do not spill water or other liquids into or on the unit.

Do not use this unit if the electrical power cord is frayed or broken.

Do not remove the cover. Removing the cover will expose you to potentially dangerous voltage.

Contact the authorized center for ordinary and extraordinary maintenance.

SPEAKER DAMAGE

The DIGAM series amplifiers are among the most powerful professional amplifiers available and are capable of producing much more power than many loudspeakers can handle. It is the user's responsibility to use

suitable speakers with the amplifier and to use them in a sensible way that will not cause damage.

Powersoft will not be responsible for damaged speakers. Consult the speaker manufacturer for power-handling recommendations.

Even if you reduce the gain using the amplifier's front panel attenuation controls, it is still possible to reach full output power if the input signal level is high enough.

A single high-power crescendo can damage high-frequency drivers almost instantaneously, while low-frequency drivers can usually withstand very high, continuous power levels for a few seconds before they fail. Reduce power immediately if you hear any speaker "bottoming out" - harsh pops or cracking distortion that indicate that the speaker voice coil or diaphragm is striking the magnet assembly.

Powersoft recommends that you use amplifiers of this power range for more headroom (cleaner sound) rather than for increased volume.

SPEAKER OUTPUT SHOCK HAZARD

A DIGAM amplifier is capable of producing hazardous output voltages. To avoid electrical shock, do not touch any exposed speaker wiring while the amplifier is operating. This manual contains important information on operating your DIGAM amplifier correctly and safety. Please read it carefully before operating your amplifier. If you have any questions, contact your Powersoft dealer.

This manual contains important information on operating your DIGAM amplifier correctly and safety. Please read it carefully before operating your amplifier. If you have any questions, contact your Powersoft dealer.

Introduction

Powersoft is a leading company in the field of high efficiency audio power management. The totally new Powersoft's DIGAM (DIGital AMplifier) technology has changed the way the world looks at professional audio amplification. No other amplifiers come close for applications demanding high power and long term reliability.

Thanks to amazing reductions in heat output along with reductions in weight and the characteristic high output power, DIGAM amplifiers can be used in an unlimited range of applications such as concert touring, opera houses, theaters, churches, cinema, theme parks, television sound stages and industrial applications.

More sound and less weight

Compared to a conventional amplifier, Powersoft DIGAM technology offers very high efficiency and delivers more power to the loudspeakers with much reduced heat dissipation. This greater efficiency enables dimensions, weight and power consumption to be reduced. The output stages of the amplifiers typically run at 95% efficiency, dissipating only 5% of the input energy as heat.

One of the most interesting characteristics is that DIGAM's efficiency is almost independent of output level. Conventional amplifiers achieve their best efficiency only at full rated power output. Since standard music has an average power density of 40% of the maximum level, conventional amplifiers can easily generate 10 times more heat than DIGAM for the same volume of sound.

Superior Sound-Sonic Accuracy

Crystal-clear highs, and a tight, well defined low end: the most accurate reproduction of an audio signal. Patented design features ensure very high performance in parameters such as distortion, frequency response, slew rate, power bandwidth and dumping factor.

Totally Digital with High Reliability

The DIGAM series is based on PWM technology that has been used for 30 years or more in power supplies and inverters. PWM provides high reliability, small size, low weight and high efficiency. A PWM converter works as a high frequency sampler, converting the variable amplitude (audio) signal into an impulse sequence with average value equal to the audio input.

DIGAM amplifiers use very high sampling frequencies to obtain high performances across the audio band. Powersoft holds several patents on the DIGAM technology.

The Best Amplifier for Your Mains

Powersoft is the first amplifier constructor to use power factor correction. This unique feature ensures that a predominantly resistive load is presented to the mains power supply, minimizing current distortion and voltage/current displacement. This leads too much improved performance of the amplifier at high levels of output and avoids mains voltage collapses, typical of standard and switching power supplies. Another great advantage of this technology is that its performance is, to a large extent, independent of the main voltage. The rated output power does not vary with load/line conditions.

The Show Always Goes On

DIGAM Series is completely protected against every possible error in operation and is designed to work under every condition. It gives you maximum power with maximum safety and increases long-term reliability. Anticipating potential problems at the design stage means your show always goes on!

Installation and Operation

Unpacking

Carefully open the shipping carton and check for any noticeable damage. Every Powersoft amplifier is completely tested and inspected before leaving the factory and should arrive in perfect condition. If you find any damage, notify the shipping company immediately. Be sure to save the carton and all packing materials for the carrier's inspection.

Mounting

All DIGAM amplifiers will mount in a standard 19" rack. Four front panel mounting holes are provided. Your DIGAM amplifier uses a forced-air cooling system to maintain a low, even operating temperature. Drawn by an internal fan, air enters through the slots in the front panel and courses over and through components. The DIGAM series amplifiers feature an "intelligent" variable-speed DC fan which is controlled by heat sink temperature sensing circuits: the fan speed will increase only when the temperature of either heat sink requires it, which keeps fan noise to a minimum and helps cut dust accumulation inside. Under extreme thermal load, the fan will force a very large volume of air through the heat sinks. If either heat sink gets too hot, its sensing circuit will reduce the output gain. If the amplifier overheats, another sensing circuit shuts down its circuit to cut off power until it cools to a safe temperature.

The exhaust cooling air is forced out through the rear of the chassis, so make sure there is enough space around the sides of the amplifier to allow the air to escape. If it is rack mounted, make sure the exhaust air can flow without resistance. If you are using a rack with closed backs, there must be at least one standard rack space of opening in the front of the rack for every four amplifiers. Amplifiers may be stacked directly on top of each other (no space needed between units), starting from the bottom of the rack.

Operating Precautions

Make sure the AC main voltage is correct and is the same as that printed on the rear of the amplifier. Damage caused by connecting the amplifier to improper AC voltage is not covered by the warranty. Make sure the power switch is off before making any input or output connections.

It is always a good idea to have the gain controls turned down during power-up to prevent speaker damage if there is a high signal level at the inputs.

Whether you buy them or make them, use good-quality input and speaker cables: faulty cables cause most intermittent problems. Use good-quality connectors and wire, along with good soldering technique, to ensure trouble free reliability.

Connecting Inputs

Input connections are made via the 3-pin XLR-type connectors on the rear side of the amplifier. The inputs are actively balanced, with polarity as shown in figure.

Male and female XLR connectors are in parallel for each channel.

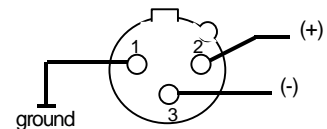

Connecting Outputs

Output connectors are made via Neutric Speakon connectors. Consult the wire gauge chart to find a suitable wire gauge to minimize power and damping factor losses in the speaker cables. Both outputs are to be considered "hot" because *the amplifier is always working on bridge mode*. The 1+ and 2+ pins of speakon connector are paralleled and have to be considered the positive output; the 1- and 2- pins of speakon connector are paralleled and have to be considered the negative output.

Never try to bridge the outputs on DIGAM series amplifiers.

Controls

Input attenuators

The two inputs attenuator controls, located on the front panel adjust gain for their respective amplifier channels in all modes. With the attenuator fully clockwise at 0dB (minimum attenuation), an input signal of 1.05V (DIGAM 3000) / 1.10V (DIGAM 5000) / 1.12V (DIGAM 7000) will give rated power into 4 ohm load. The silk screen scale is calibrated on 3dB increasing attenuation.

Led Indicators and Controls

Led indicators

Your DIGAM amplifier has LED indicators on the front panel. Two of them ("READY", "TEMP") are common to both channels and Three of them ("SIGNAL", "HI-FREQ", "PROTECT") are present for each channel. Each channel has a 10-segment LED bar for the output signal. Each segment will be light every 3dB. The green segments will be during normal working. The yellow LEDs of the bar will be light at -6 dB. If the level of the audio signal exceeds the channels output capability, it clips, triggering the red LED.

Front panel controls

The power switch, gain controls and LED indicators are on the front panel. The gain control uses a logarithmic scale between -30 and 0 dB.

- 1) Power switch (POWER)
- 2) Channel 1 gain
- 3) Channel 2 gain
- 4) Protection LED (PROTECT) CH1/CH2
- 5) High Frequency LED (HI-FREQ) CH1/CH2
- 6) Signal Present LED (SIGNAL)
- 7) Over temperature LED (TEMP): for the final module
- 8) Amplifier ready LED (READY): the led will be on if the amplifier works correctly
- 9) Right output level LED bar
- 10) Left output level LED bar

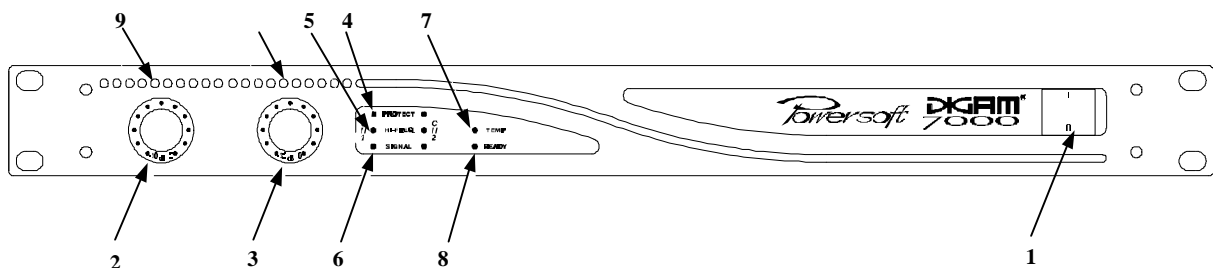

Fig. 1: Front panel

Rear panel controls

- 1) Channel 1 female Neutrik Speakon connector for audio output
- 2) Channel 2 female Neutrik Speakon connector for audio output
- 3) Channel 1 Cannon XLR connectors for input signal
- 4) Channel 2 Cannon XLR connectors for input signal
- 5) AC main cord
- 6) Cooling fan outlet

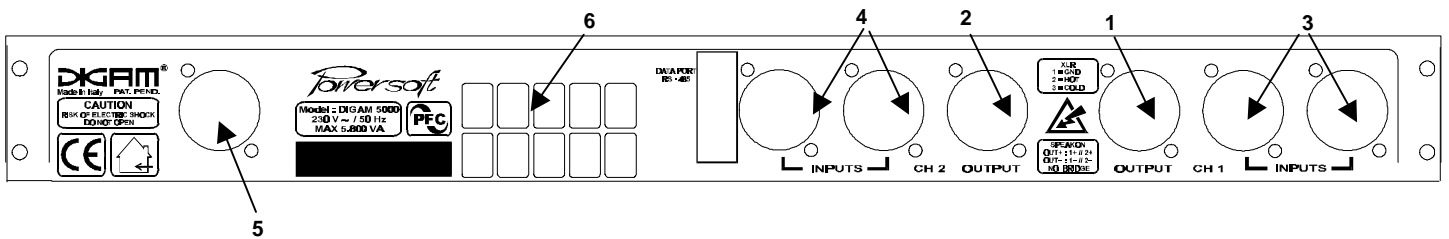

Fig. 2: Rear panel

Protection

Turn-On/Turn-Off Muting

For about four seconds after turn-on, and immediately at turn-off, the amplifier outputs are muted.

Short circuit protection

A short circuit protection system safeguards the amplifier's output transistors under short circuits and other stressful loads. It is completely inaudible when inactive. In case of short circuit, the PROTECTION LED will be light.

Thermal protection

A DIGAM amplifier uses a continuously variable speed fan to assist cooling (the fan speed changes in response to the amplifier's cooling needs). If the heat sink temperature reaches approximately 60°C, the TEMP LED starts to flashing. If the temperature is more than 70°C the thermal sensing circuitry will mute both channels, the TEMP LED will be light permanently and the power supply will be inhibited. Once the heatsink has cooled down, the amplifier will automatically unmute and the TEMP LED will be unlighted. It will be possible to reduce the temperature reducing the output power.

DC fault protection

If DC or excessive subsonic energy appears at a channel output, an instantaneous protection circuit will inhibit the power supply for both channels. Power supply shutdown is used in lieu of speaker relays, thereby improving the damping factor and reliability of the DIGAM amplifiers.

Input/output protection

An ultrasonic network decouples RF from the outputs and keeps the amplifier stable with reactive loads.

User Maintenance

Cleaning: Disconnect the amplifier from the AC main source first; use a soft cloth and mild non-abrasive solution to clean the faceplate and chassis.

Dust removal: Especially in a dusty environment, the heat sink may clog with dust after prolonged use, which will interfere with cooling. You may use compressed air to remove the dust; severe cases, though, should be referred to qualified service personnel for a thorough cleaning with the top cover removed.

There are no user-serviceable parts in your DIGAM amplifier. Refer servicing to qualified technical personnel.

In addition to having an in-house service department, Powersoft supports a network of authorized service centers. If your DIGAM amplifier needs repair, contact your Powersoft dealer or distributor, or contact the Powersoft Technical Service department, to obtain the location of the nearest authorized service center.

Warranty and disclaimers

Disclaimer

Powersoft is not liable for any damage to speakers, amplifier, or any other equipment that is caused by negligence or improper installation and/or use of the DIGAM amplifier.

Product warranty

Powersoft guarantees the DIGAM to be free from defective material and/or workmanship for a period of one year from date of sale. Powersoft will replace defective parts and repair malfunctioning products under this warranty when the defect occurs under normal installation and use. The unit must be returned to our factory via prepaid transportation with proof of purchase (sales receipt). This warranty provides that examination of the returned product must disclose, in our judgment, a manufacturing defect. This warranty does not extend to any product that has been subject to misuse, neglect, accident, improper installation, or where the date code has been removed or defaced.

Technical assistance and service

Servicing your unit requires a trained technician capable of performing the type of service you need. There are no user serviceable components inside your unit and the danger of electric shock exists. Additionally, some of the components in your unit are Powersoft specific parts that require Powersoft replacements.

Technical assistance

If you suspect that your amplifier is defective, check your system configuration and amplifier settings to determine the origin of the problem. In many cases, incorrect audio interfacing, poor cabling, or other system level impairments are the cause of problems in audio systems. For technical assistance beyond the information given in this manual, the Powersoft technical Services department may be contacted.

Factory service

In the event that your amplifier does need factory service, you may reach the Powersoft Technical Services department for return instructions. A Return Authorization (RA) number must be obtained from Powersoft Technical Services department. Powersoft may not account for products that are returned without a Return Authorization number.

Product Return Guidelines

1. Pack the product well for protection during shipment.
2. Include a copy of the sales receipt, your name, return address, phone number, and defect description with your return correspondence.
3. Call the Powersoft Technical Authorization Services department for an outside of the packaging.
4. Ship the product prepaid to Powersoft. We recommend United Parcel service (UPS).

Powersoft S.r.l.
C.A.Technical Service Department
Web: www.powersoft.it
E-mail: support@powersoft.it

International servicing

For Powersoft products that are purchased outside of the Italy, service must be referred to the distributor or dealer from where the product was purchased. There are numerous service centers in many countries. The service centers in your country may be located by your dealer, distributor, or by contacting Powersoft Technical Services.

Technical Notes

- DIGAM amplifiers cannot work in bridge connection
- The DIGAM amplifier has an automatic power factor correction system for a perfect main network interface. The amplifier is a resistive load for the main network, minimizing the reactive power and the harmonic distortion on the current. The system allows performance to be maintained even in circumstances of varying the mains voltage.
- The output stage of the amplifier is a bridge configuration with both outputs (positive and negative) not referred to ground. A DC voltage is present between these outputs and the ground (Chassis). This voltage is variable and depends on the model from 40VDC to 80VDC .
- The connection of the processors equipped with a “feed-back” system must be done decoupling this voltage by capacitor.
- The formula that rules the capacitor value and the schematic application are the following.

$C \cong 1 / (30 * Z_{in})$ where Z_{in} is the input impedance of the processor used.

IMPORTANT : If decoupling is not performed the amplifier may go in protect mode.

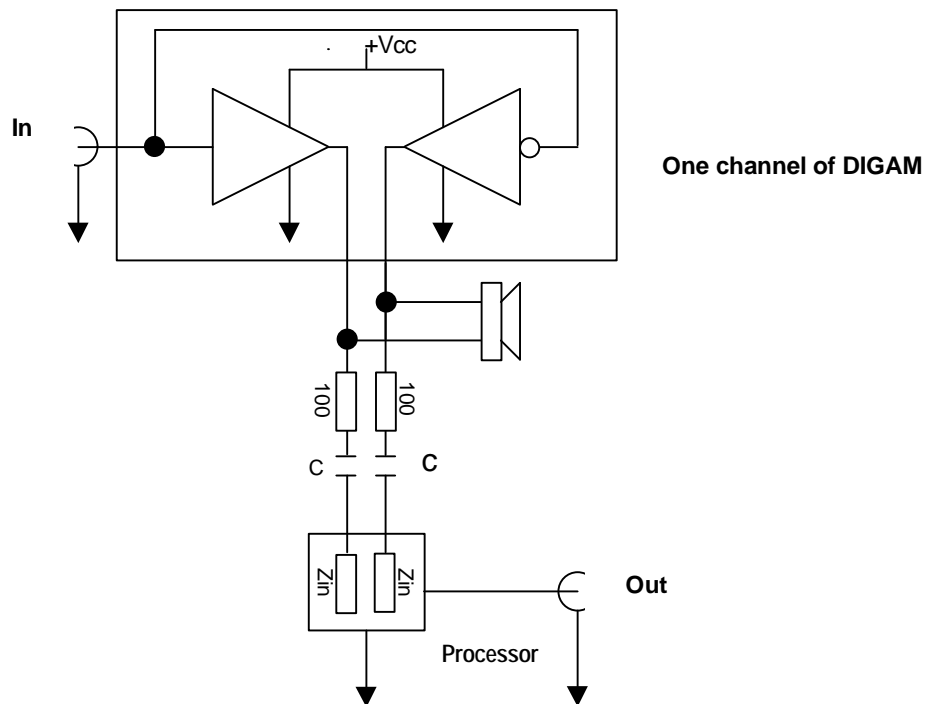

DIGAM 3000

General

Type	Digital amplifier for professional applications
Power requirements:	
European, UK, Australian models	AC 200V ÷ 265V, 50/60Hz
Other models	AC 95V ÷ 130V, 50/60Hz
Nominal Power (one-eighth of the out-power to the rated load impedance)	650VA
Power Maximum	full power stereo 4 Ω, 2000W
Power factor $\cos(\varphi)$	more than 0.95 from 200W to 3500W
Operating temperature	0°C ÷ +45°C
Weight	9.5 kg
External dimensions	Standard rack 19" (W), 1 units (H), 450mm (D)

Audio section

Power RMS x Channel (1KHz, 0.5% THD)	8 Ω = 450 W 4 Ω = 820 W 2 Ω = 1250 W
Power RMS x Channel in stereo working (1KHz, 0.5% THD)	8 Ω = 450 W 4 Ω = 820 W 2 Ω = 1500 W EIAJ 1% THD
Bandwidth (1W, 8 Ω)	10 Hz ÷ 40 kHz
Damping factor (8 Ω)	100 Hz = 300 10 kHz = 300
Slew Rate (8 Ω)	50V/μs (input filter bypassed)
S/N ratio	100 dB/A
Distorsion	
THD	Max < 0.5% from 0.1W at full power (typically < 0.1%)
Intermodulation SMPTE	Max < 0.5% from 0.1W at full power (typically < 0.1%)
Intermodulation DIM 100	Max < 0.02% from 0.1W at full power (typically < 0.01%)
Inputs	Balanced to ground, XLR male/female paralleled
Impedance	10 KΩ each leg, balanced to ground
Sensitivity	1.05V (full rated output power 8 Ω)
Gain	35.1 dB or 26dB removing the internal jumpers
Outputs	Neutric 4-pole speakon connectors (pins 1+ 2+ paralleled, 1- 2- paralleled)

Functions

- High frequency indicator
- LED bar indicator
- Over-temperature forecasting
- Thermal protection
- Gain control
- Short-circuit/over-load output protection
- Temperature controlled air-cooling system
- Autoreset system
- Clip limiter and permanent signal compressor
- Remote control interface from a PC through a LAN (optional)
- Alphanumeric display for amplifier local handling (optional)

General

Type	Digital amplifier for professional applications
Power requirements:	
European, UK, Australian models	AC 200V ÷ 265V, 50/60Hz
Other models	AC 95V ÷ 130V, 50/60Hz
Nominal Power (one-eighth of the out-power to the rated load impedance)	1050VA
Power Maximum	full power stereo 4 Ω, 3400W
Power factor $\cos(\varphi)$	more than 0.95 from 200W to 5000W
Operating temperature	0°C ÷ +45°C
Weight	9.5 kg
External dimensions	Standard rack 19" (W), 1 units (H), 450mm (D)

Audio section

Power RMS x Channel (1KHz, 0.5% THD)	8 Ω = 750 W 4 Ω = 1360 W 2 Ω = 2050 W
Power RMS x Channel in stereo working (1KHz, 0.5% THD)	8 Ω = 750 W 4 Ω = 1360 W 2 Ω = 2500 W EIAJ 1% THD
Bandwidth (1W, 8 Ω)	10 Hz ÷ 40 kHz
Damping factor (8 Ω)	100 Hz = 300 10 kHz = 300
Slew Rate (8 Ω)	50V/μs (input filter bypassed)
S/N ratio	100 dB/A
Distorsion	
THD	Max < 0.5% from 0.1W at full power (typically < 0.1%)
Intermodulation SMPTE	Max < 0.5% from 0.1W at full power (typically < 0.1%)
Intermodulation DIM 100	Max < 0.02% from 0.1W at full power (typically < 0.01%)
Inputs	Balanced to ground, XLR male/female paralleled
Impedance	10 KΩ each leg, balanced to ground
Sensitivity	1.10V (full rated output power 8 Ω)
Gain	36.9 dB or 26dB removing the internal jumpers
Outputs	Neutric 4-pole speakon connectors (pins 1+ 2+ paralleled, 1- 2- paralleled)

Functions

- High frequency indicator
- LED bar indicator
- Over-temperature forecasting
- Thermal protection
- Gain control
- Short-circuit/over-load output protection
- Temperature controlled air-cooling system
- Autoreset system
- Clip limiter and permanent signal compressor
- Remote control interface from a PC through a LAN (optional)
- Alphanumeric display for amplifier local handling (optional)

DIGAM 7000

General

Type	Digital amplifier for professional applications
Power requirements:	
European, UK, Australian models	AC 200V \pm 265V, 50/60Hz
Other models	AC 95V \pm 130V, 50/60Hz
Nominal Power (one-eighth of the out-power to the rated load impedance)	1350VA
Power Maximum	Full power stereo 4 Ω , 4800W
Power factor $\cos(\varphi)$	More than 0.95 from 200W to 6000W
Operating temperature	0°C \pm +45°C
Weight	9.5 kg
External dimensions	Standard rack 19" (W), 1 units (H), 450mm (D)

Audio section

Power RMS x Channel (1KHz, 0.5% THD)	8 Ω = 1050 W 4 Ω = 1910 W 2 Ω = 2900 W
Power RMS x Channel in stereo working (1KHz, 0.5% THD)	8 Ω = 1050 W 4 Ω = 1910 W 2 Ω = 3500 W EIAJ 1% THD
Bandwidth (1W, 8 Ω)	10 Hz \pm 40 kHz
Damping factor (8 Ω)	100 Hz = 300 10 kHz = 300
Slew Rate (8 Ω)	50v/ μ s (input filter bypassed)
S/N ratio	100 dB/A
Distorsion	
THD	Max < 0.5% from 0.1W at full power (typically < 0.1%)
Intermodulation SMPTE	Max < 0.5% from 0.1W at full power (typically < 0.1%)
Intermodulation DIM 100	Max < 0.02% from 0.1W at full power (typically < 0.01%)
Inputs	Balanced to ground, XLR male/female paralleled
Impedance	10 K Ω each leg, balanced to ground
Sensitivity	1.12V (full rated output power 8 Ω)
Gain	38.2 dB or 26dB removing the internal jumpers
Outputs	Neutric 4-pole speakon connectors (pins 1+ 2+ paralleled, 1- 2- paralleled)

Functions

- High frequency indicator
- LED bar indicator
- Over-temperature forecasting
- Thermal protection
- Gain control
- Short-circuit/over-load output protection
- Temperature controlled air-cooling system
- Autoreset system
- Clip limiter and permanent signal compressor
- Remote control interface from a PC through a LAN (optional)
- Alphanumeric display for amplifier local handling (optional)